

# ECO LIGHT EASY TOWER-P

*Iluminación portátil  
Proyectora*

**3.1m**

Altura máxima  
de trabajo



**8.2kg**

Capacidad  
Máxima



Funcionamiento  
100% Eléctrico



**13 h**

Autonomía



# ECO LIGHT EASY TOWER-P



## ESPECIFICACIONES

MODELOS	EASY TOWER-P
<b>Mediciones</b>	<b>Métrica</b>
Altura de trabajo	1.25m - 3.1 m
Peso	8.2 Kg
Alimentación	D24 Series battery pack / AC 100-277V
Lúmenes	0 - 14,000 Lm
Autonomía	>13 Horas ( Modo standard , D24-100x2)
Grado IP	IP66
Salida (USB)	5V 2A (2 Dock)

## PAQUETE

MODELOS	EASY TOWER-P
<b>Mediciones</b>	<b>Métrica</b>
Caja	1350x290x380 mm
Peso	11.5 Kg

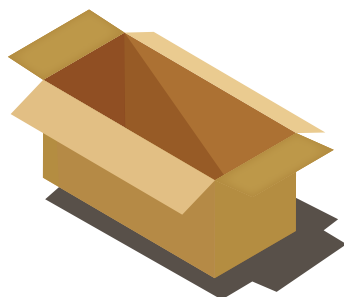

## MEDIDAS (mm)

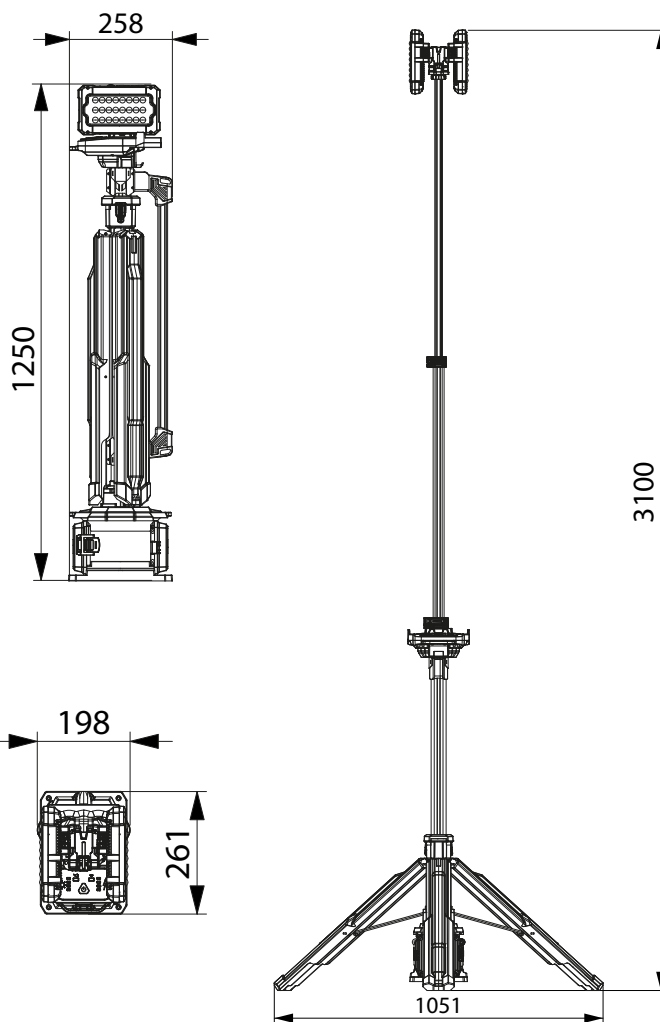

# ECO LIGHT EASY TOWER-P

ECO LIGHT  
EASY TOWER

## MÁS ALTO , MÁS BRILLANTE , MÁS ESTABLE

Expandir o retraer requiere sólo dos pasos  
y puede completarse en 10 segundos.



1 Suelta las piernas



2 Suelta y levante la alargadera

Asegura la lámpara a  
cualquier altura con la  
hebilla.



Liberación o bloqueo  
de las patas.



Se dispone de piquetas para  
fijar la torre de iluminación,  
resistencia al viento y a las  
vibraciones. (Opcional)



# ECO LIGHT EASY TOWER-P

ECO LIGHT  
EASY TOWER

## DISEÑO HUMANIZADO OCULTO EN LOS DETALLES



### Salida USB

Dos salidas USB para cargar dos dispositivos a la vez, llueva o haga sol.



### Soporte para teléfono

Sigue trabajando mientras se carga, el gancho puede servir de soporte para el teléfono.



### Regulación continua

Enchufe el controlador en el puerto impermeable para desbloquear la máxima luminosidad y la regulación continua.

# ECO LIGHT EASY TOWER-P



## ILUMINACIÓN UNIFORME Y NO DESLUMBRANTE DE 360 GRADOS

ÁREA DE ILUMINACIÓN 2200m<sup>2</sup>



ALIMENTACIÓN AC

Hasta **14,000** LM

ALIMENTACIÓN CON BATERÍA

Hasta **8,000** LM

### REGULACIÓN CONTINUA (ALIMENTACIÓN AC)

0

●  
14,000 LM

4 niveles de brillo (Baterías)

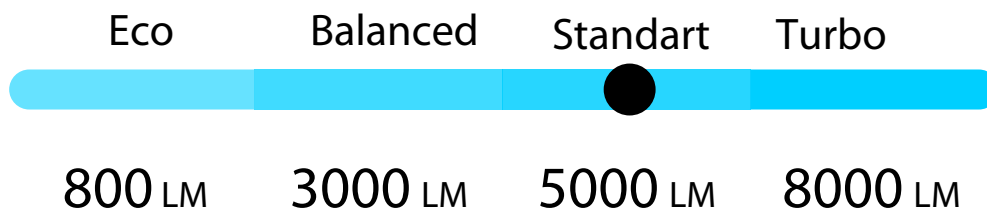

# ECO LIGHT EASY TOWER-P

ECO LIGHT  
EASY TOWER

**DISEÑADO PARA  
MANEJO POR UNA SOLA  
PERSONA**

Fácil de agarrar y trasladar , pesa 8.2 kg  
sin la batería

## APLICACIONES



Construcción



Emergencia



Deporte



Mantenimiento



Infraestructuras



Actividades al aire libre



Minería



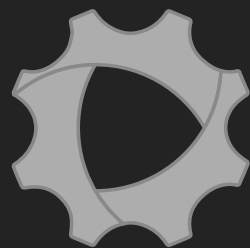

Ferrocarril

**ECO LIGHT**  
**EASY**  **OWER**



**Rent  
Industrial**  
Colombia

   @rentindustrial

[www.rent-industrial.com](http://www.rent-industrial.com)

[gerenciadeproyectos@rent-industrial.com](mailto:gerenciadeproyectos@rent-industrial.com)

Celular: 317-433-8618 - 310-577-8787

Autopista Bogotá - Medellín Km 7 Celta Trade Park Bodega 20